

ART FOUNDATION

BACK TO BASICS - *DRAWING 101*

Secondary 1
Term 1 2021
Lesson 2

DRAWING 101: REMEMBER?



What are the main characteristics of the drawing technique seen?

Compare these other examples...



2 CHARACTERISTICS

CHARACTERISTIC 1

One continuous line

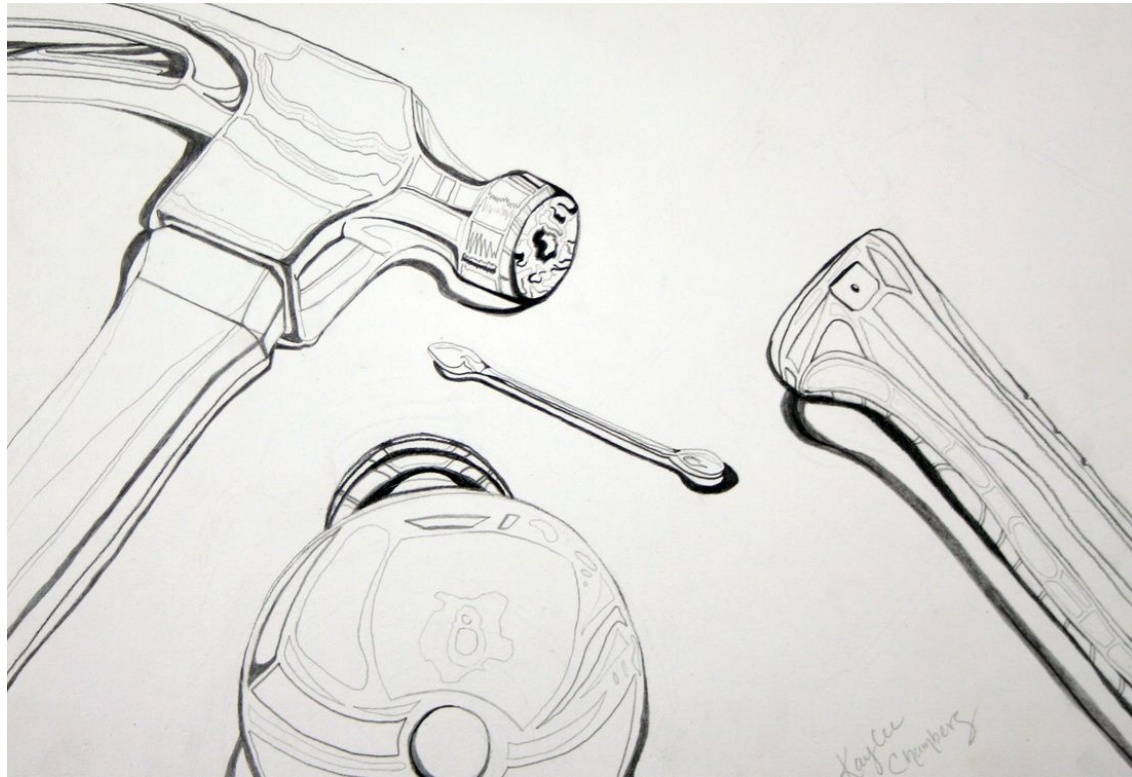

CHARACTERISTIC 2

Thick & Thin lines



CONTOUR DRAWING

These 2 characteristics make up the drawing technique called Contour Drawing.

Artists sketches a one continuous line to create the outline of the subject matter, emphasizing on mass and volume rather than the shading the details.

By using thick and thin lines, the artist can show the 3D form of an object, highlights, shadows and even multiple perspectives in a drawing.

By definition, Contour Line Drawing simply means the outline of a form, as well as interior structure, without the use of shading.



ARTIST REFERENCE: JULIETTE PLISSON

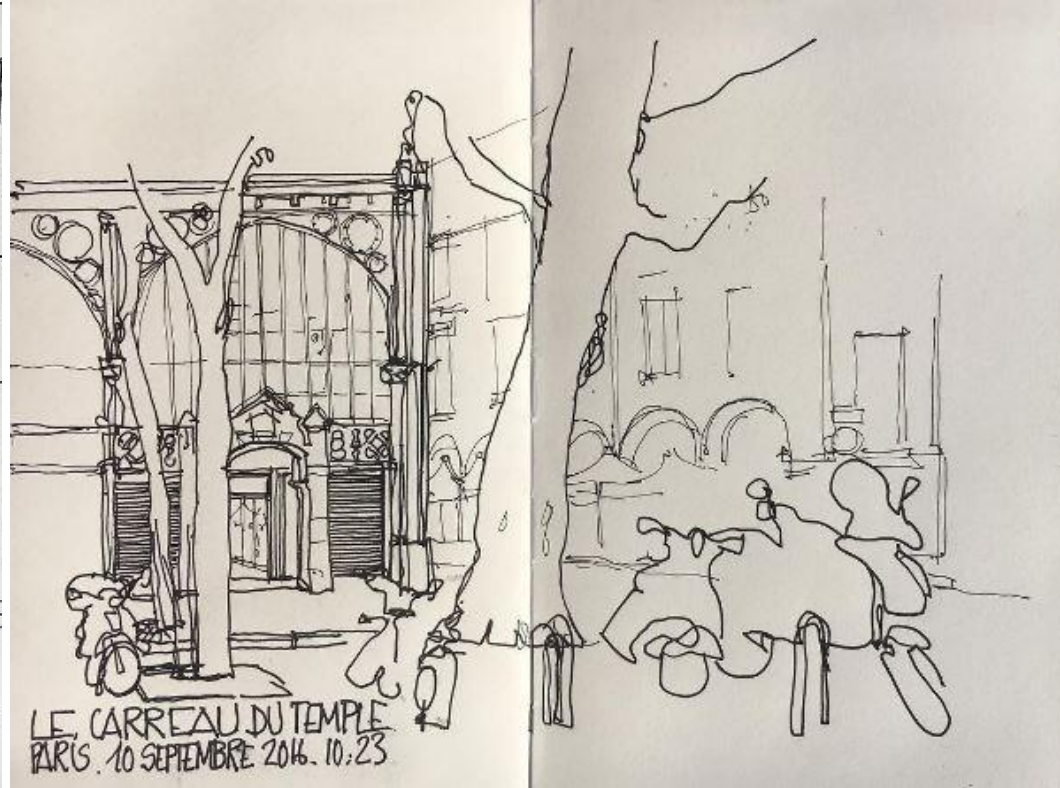

Ig:
[@juliette.plisson](https://www.instagram.com/juliette.plisson)

ARTIST REFERENCE: MO GANJI



Ig:
@moganji

CLASS ACTIVITY 1

On the worksheet provided, use a 2B wooden pencil and fill in the blanks together as a class!

Focus on Characteristic 1: One continuous line column only.

Remember

Do not lift up your pencil until you are completely done drawing the whole shape!

SECONDRARY 1
ART
T1#2&3

NAME: _____ () CLASS: _____ DATE: _____

Section A: Activity 1
Fill in the blank areas together as a class!
Use a 2B wooden pencil only. No erasing allowed.

S/ N	Characteristic 1 One Continuous Line	S/ N	Characteristic 1 + 2 One Continuous Line + Thick & Thin Line
1a		1b	
2a		2b	
3a		3b	
4a		4b	

CLASS ACTIVITY 1: ONE CONTINUOUS LINE

1a [5 secs]

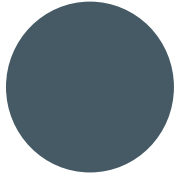

2a [5 secs]



3a [5 secs]



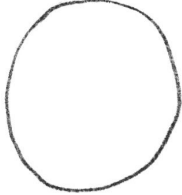
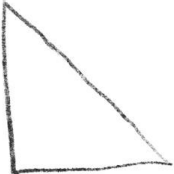
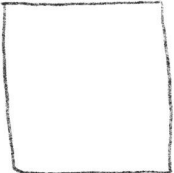

S/N	Characteristic 1 One Continuous Line
1a	 [5 secs]
2a	 [5 secs]
3a	 [5 secs]

4a [7 secs]



5a [10 secs]

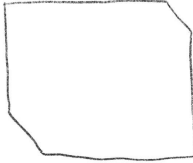

4a	 [7 secs]
5a	 [10 secs]

CLASS ACTIVITY 1: ONE CONTINUOUS LINE

6a [20 secs]

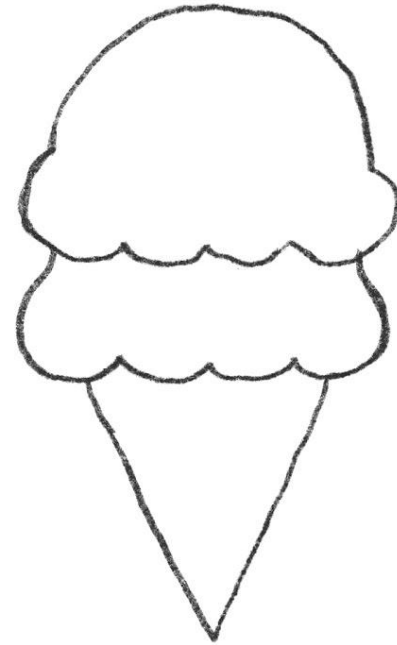

CLASS ACTIVITY 1: ONE CONTINUOUS LINE



6a	 <p>[20 secs]</p>
7a	
8a	

9a	
10a	

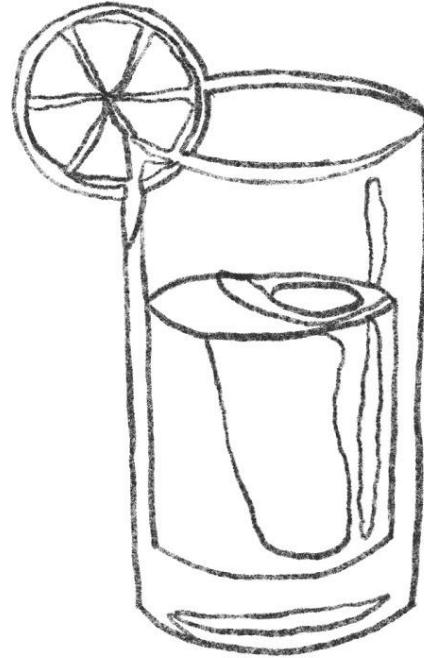

CLASS ACTIVITY 1: ONE CONTINUOUS LINE

7a [1 min]



CLASS ACTIVITY 1: ONE CONTINUOUS LINE



6a	 <p>[20 secs]</p>
7a	 <p>[1 min]</p>
8a	

9a	
10a	



CLASS ACTIVITY 1: ONE CONTINUOUS LINE

8a [1 min]



CLASS ACTIVITY 1: ONE CONTINUOUS LINE



6a	 <p>[20 secs]</p>
7a	 <p>[1 min]</p>
8a	 <p>[1 min]</p>

9a	
10a	

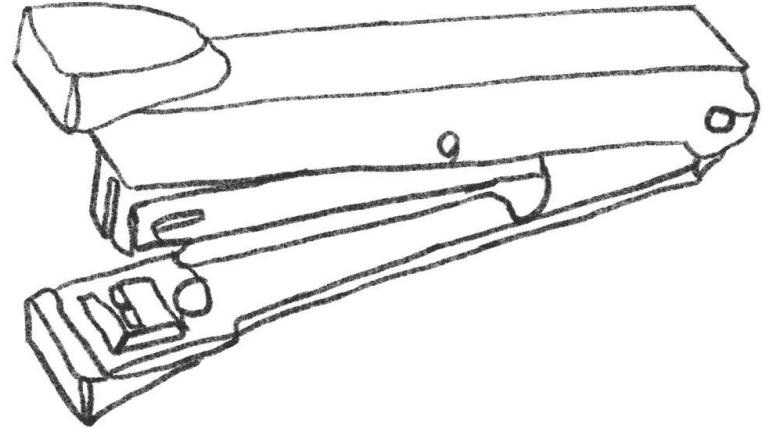

CLASS ACTIVITY 1: ONE CONTINUOUS LINE

9a [2 mins 30 secs]



CLASS ACTIVITY 1: ONE CONTINUOUS LINE



6a	 <p>[20 secs]</p>
7a	 <p>[1 min]</p>
8a	 <p>[1 min]</p>

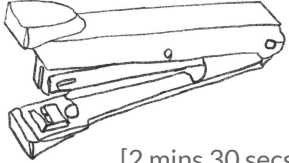

9a	 <p>[2 mins 30 secs]</p>
10a	

CLASS ACTIVITY 1: ONE CONTINUOUS LINE

10a [3 mins 10 secs]



You may use your
own hand gesture

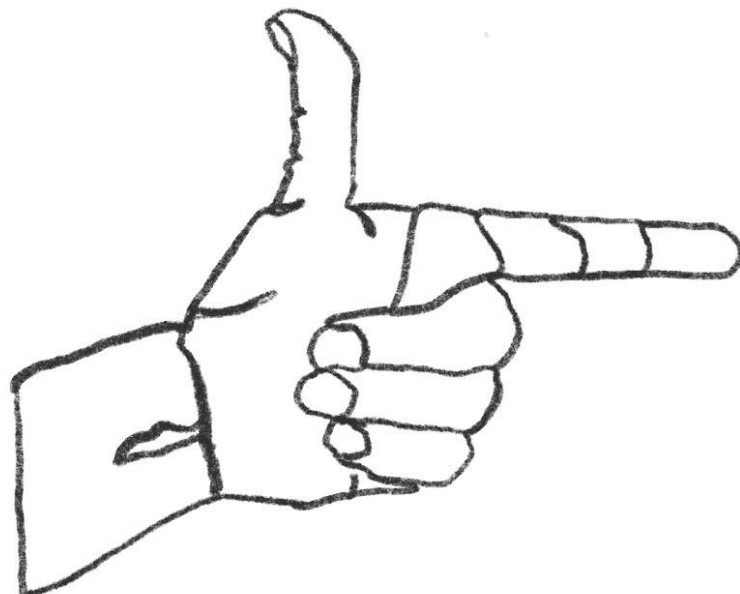

CLASS ACTIVITY 1: ONE CONTINUOUS LINE



6a	 <p>[20 secs]</p>
----	--

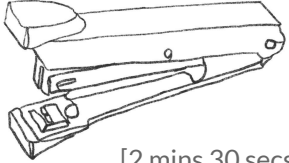

9a	 <p>[2 mins 30 secs]</p>
----	---



7a	 <p>[1 min]</p>
----	--

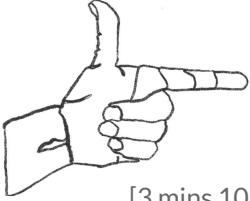

10a	 <p>[3 mins 10 secs]</p>
-----	---



8a	 <p>[1 min]</p>
----	---

CLASS ACTIVITY 2
ART TASK

CLASS ACTIVITY 2

You will be receiving:

1 piece of transparency

1 piece of portrait print out

1 piece of A4 paper



CLASS ACTIVITY 2

Follow these steps to prepare for your Art Task:

- 1) Separate and discard the white paper from the transparency paper. You should only retain the transparency paper.
- 2) Overlap the transparency paper on top of the portrait print out.

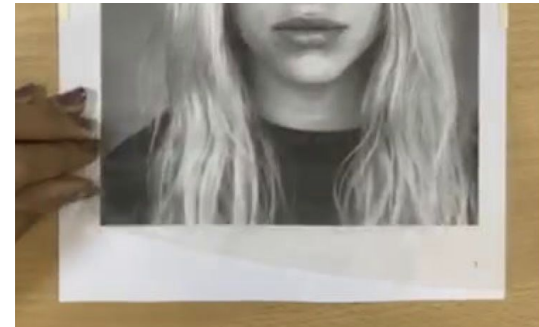
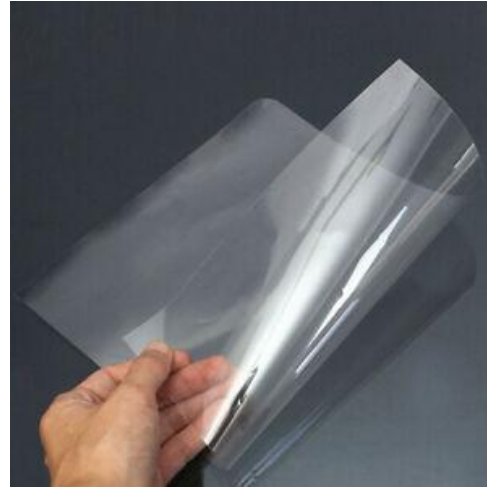

CLASS ACTIVITY 2

- 3) Use the masking tape and tape the two top corners and the two mid edges neatly



- 4) You are now ready to begin your artwork!

CLASS ACTIVITY 2

Art Task brief:

You are to complete a Contour Line portrait drawing.

You must draw on the transparency paper by using the red marker (thicker tip). Use the red marker and trace the lines you see onto the transparency paper.

Your portrait drawing must reference the portrait print out given.

This is how it should look like! →



CLASS ACTIVITY 2

Pro tip 1:

Your drawing should look like it is 1 continuous line!

Pro tip 2:

Make sure your lines are neat and not *hairy/sketchy*. Do not colour in or fill in any areas. Your drawing should only be **lines**.

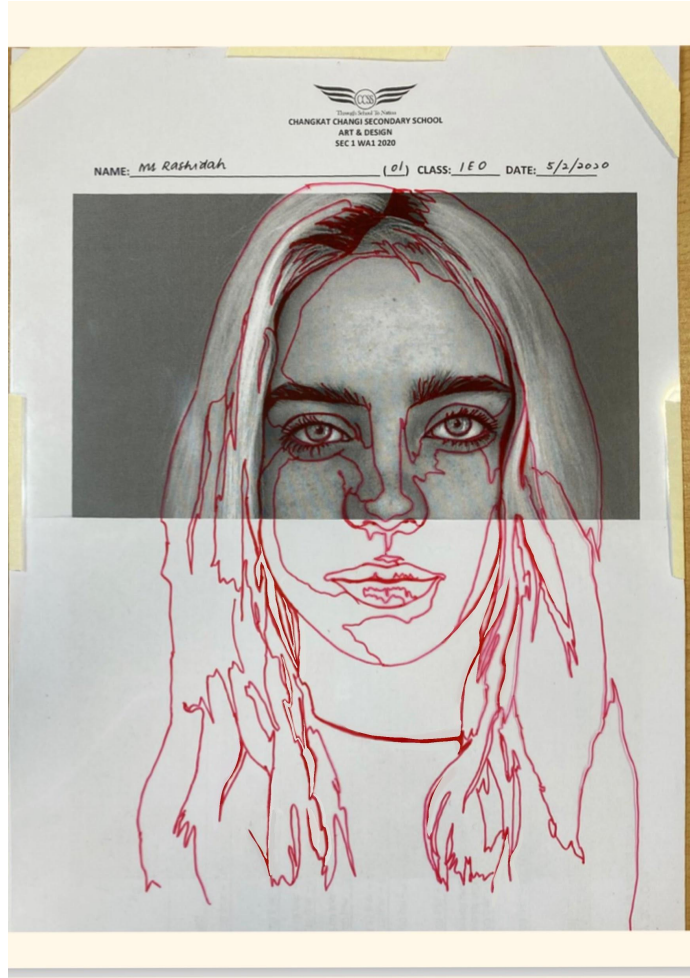

Pro tip 3:

Draw out as much details as you can see.

Pro tip 4:

Check your work with a blank A4 paper.

CLASS ACTIVITY 2

Example works:

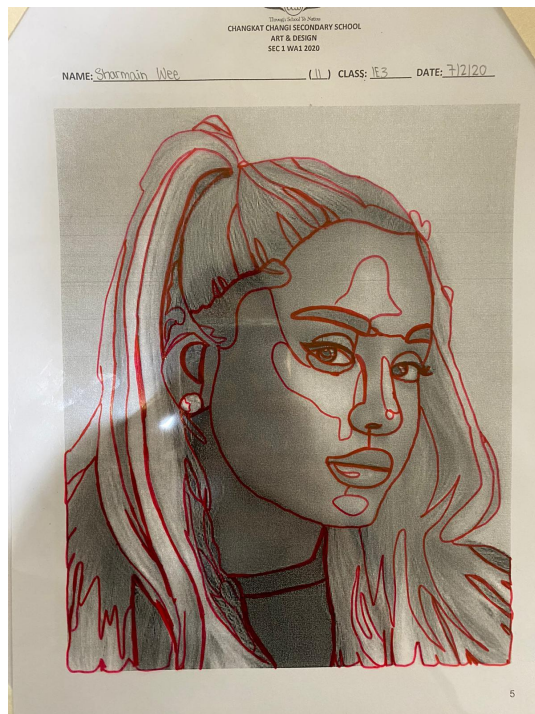
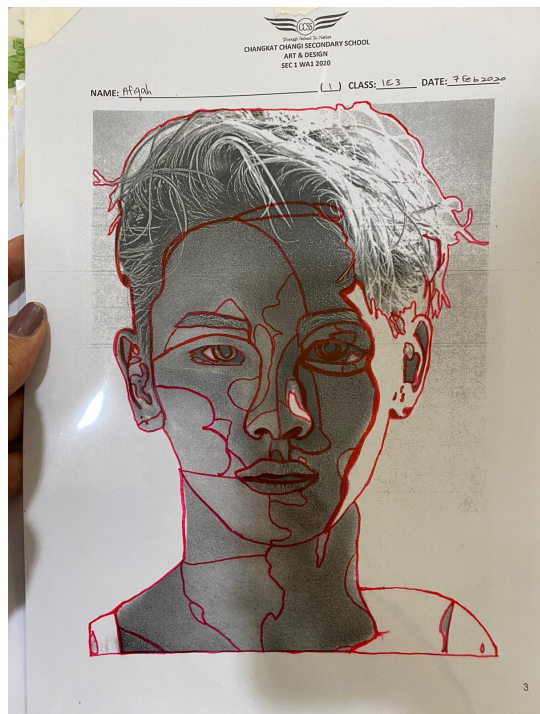

CLASS ACTIVITY 2

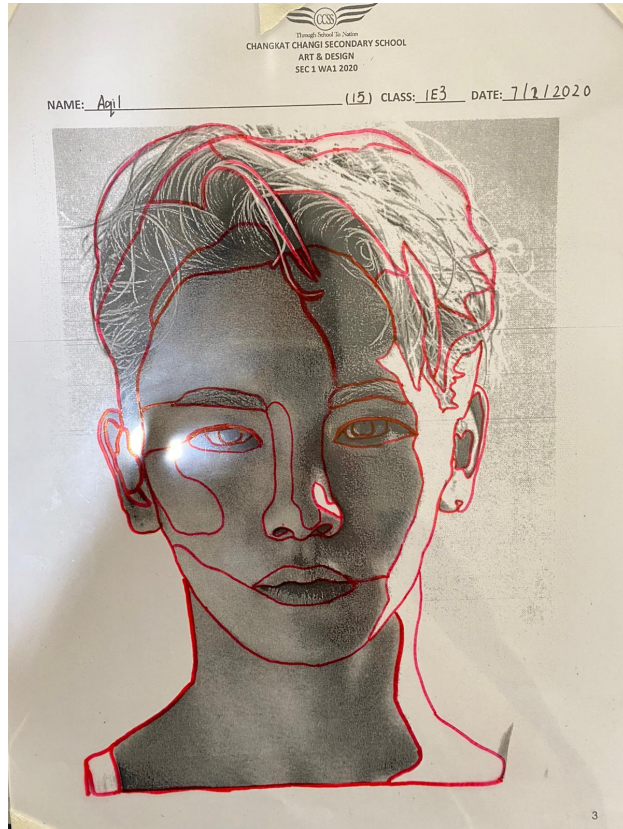

When you are done with your Art Task,

- a) Detach the portrait print out from the transparency drawing
- b) Attach the blank A4 paper behind your transparency drawing
- c) Write your name, index no, class and date on the transparency paper
- d) **Submit your transparency drawing and the print out separately by the end of this lesson!**

NEXT LESSON
PREPARATION

DRAWING 101: NEXT LESSON

Things to bring:

T1#2&3 worksheet (completed)

A set of wooden pencils

1 red dual-tip permanent marker

1 blue dual-tip permanent marker

1 green dual-tip permanent marker





1 masking tape

Through School To Nation

**SECONDARY 1
ART
T1#2&3**

NAME: _____ () CLASS: _____ DATE: _____

Section A Activity 1
Fill in the blank areas together as a class!
Use a 2B wooden pencil only. No erasing allowed.

Sl N	Characteristic 1 One Continuous Line	Sl N	Characteristic 1 & 2 One Continuous Line + Thick & Thin Line
1a	 [5 secs]	1b	?
2a	 [5 secs]	2b	?
3a	 [5 secs]	3b	?
4a	 [7 secs]	4b	?



DRAWING 101: HOMEWORK

Flip Classroom





Go to the art website,

<http://ccssart.weebly.com/sec-11.html>

Check out the PowerPoint slides
and attempt column 'b'!

Complete the whole worksheet and
bring it to class next week.

All the best!

 Through School To Nation			
SECONDARY 1 ART T1#2&3			
NAME: _____		CLASS: _____ DATE: _____	
Section A Activity 1 Fill in the blank areas together as a class! Use a 2B wooden pencil only. No erasing allowed.			
S/N	Characteristic 1 One Continuous Line	S/N	Characteristic 1 + 2 One Continuous Line + Thick & Thin Line
1a	 [5 secs]	1b	?
2a	 [5 secs]	2b	?
3a	 [5 secs]	3b	?
4a	 [7 secs]	4b	?